

See discussions, stats, and author profiles for this publication at: <https://www.researchgate.net/publication/269493678>

Interior Insulation Retrofits of Load-Bearing Masonry Walls in Cold Climates

Article in *Journal of Green Building* · May 2007

DOI: 10.3992/jgb.2.2.42

CITATIONS

63

READS

2,017

2 authors, including:



John Straube

University of Waterloo

75 PUBLICATIONS 1,003 CITATIONS

SEE PROFILE

INTERIOR INSULATION RETROFITS OF LOAD-BEARING MASONRY WALLS IN COLD CLIMATES

John Straube, PhD, PEng¹ and Chris Schumacher, BTech, BASc²

INTRODUCTION

Reducing the energy consumption of buildings has become increasingly imperative because of the combined demands of energy security, rising energy costs, and the need to reduce the environmental damage associated with energy consumption. A significant amount of research has developed guidance and technology to assist designers and owners in significantly reducing the energy consumption of new buildings. However, a vast stock of existing buildings, the great majority of which have poorly insulated enclosures, exists. Improving the energy performance of this stock of buildings will be a very important part of transitioning North America from an imported fossil fuel dependent region, to a low-carbon, self-sufficient economy.

Upgrading, renovating, and converting buildings to new uses involve numerous challenges. One socially, culturally, and economically important class of buildings is load-bearing brick and stone masonry buildings. These were typically built before the Second World War. Adding insulation to the walls of such masonry buildings in cold, and particularly cold and wet, climates may cause performance and durability problems.

This paper reviews the moisture control principles that must be followed for a successful insulated retrofit of a solid load-bearing masonry wall. Two possible approaches to retrofitting such walls are presented and compared.

THE MOISTURE BALANCE

The primary concern with insulating older load-bearing masonry buildings in cold climates is the possibility of causing freeze-thaw damage of the brickwork and decay in any embedded wood structure. Both concerns are related to excess moisture content and hence a review of moisture in building enclosures is appropriate.

For a moisture-related problem to occur, at least five conditions must be satisfied:

1. A moisture source must be available.
2. There must be a route or means for this moisture to travel.
3. There must be some driving force to cause moisture movement.
4. The material(s) involved must be susceptible to moisture damage.
5. The moisture content must exceed the material's safe moisture content for a sufficient length of time.

To avoid a moisture problem one could, in theory, choose to eliminate any one of the conditions listed above. In reality, it is practically impossible to remove all moisture sources, to build walls with no imperfections, or to remove all forces driving moisture movement (Straube and Burnett 2005). It is also not economical to use only those materials that are not susceptible to moisture damage. Therefore, in practice, it is common to address two or more of these prerequisites so as to reduce the probability of exceeding the safe moisture content and the amount of time the moisture content is exceeded.

All enclosure design requires a balance of wetting and drying (Figure 1). Since wetting occurs at different times than drying, storage bridges the time between wetting and drying. If a balance between wetting and drying is maintained, moisture will not accumulate over time, the safe moisture content will not be exceeded, and moisture-related problems are unlikely. The storage capacity and the extent and duration of wetting and drying must, however, always

1. Associate Professor in Department of Civil Engineering & School of Architecture, University of Waterloo, Canada, and Director of the Building Engineering Group. Professor Straube may be reached at jfstraube@uwaterloo.ca.

2. Founding principal of Building Science Consulting Inc. and a contributor to BuildingScience.com.

FIGURE 1. The moisture balance analogy (Straube 2002).

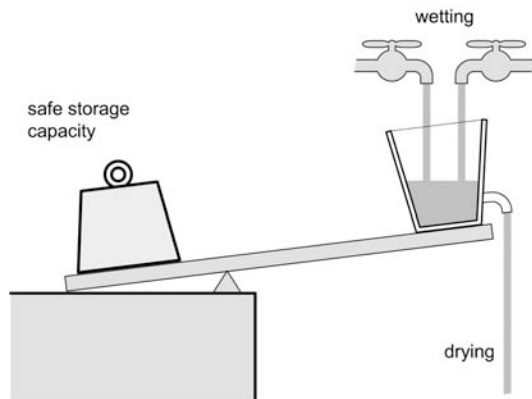

be considered when assessing the risk of moisture damage.

The four major sources of moisture for the above-grade building enclosure are (Figure 2):

1. precipitation, especially driving rain
2. water vapor in the air transported by diffusion and/or air movement through the wall (from either the interior or exterior)

FIGURE 2. Moisture sources and mechanisms for an arbitrary enclosure wall.

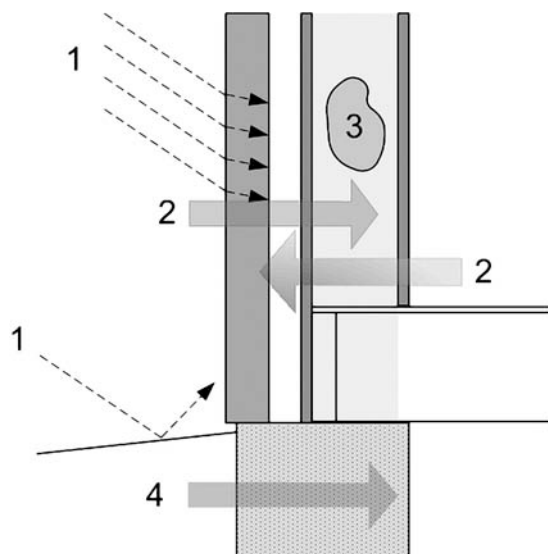

3. built-in and stored moisture
4. liquid and bound ground water

An assembly's drying potential is an important factor in assessing its vulnerability to moisture problems. Moisture is usually removed from an enclosure assembly by (Figure 3):

1. evaporation of water transported by capillary suction through microscopic pores to the inside or outside surfaces;
2. vapor transport by diffusion (through microscopic pores), air leakage (through cracks and holes), or both, either outward or inward;
3. drainage through small cracks and openings, driven by gravity; and
4. ventilation (ventilation drying), the intentional flow of air behind the cladding.

WHY RETROFIT LOAD-BEARING MASONRY WALLS

The enclosure walls of many older buildings are comprised of several wythes of interlocking masonry units (e.g., brick, stone), cement, lime, or cement-

FIGURE 3. Moisture removal mechanisms.

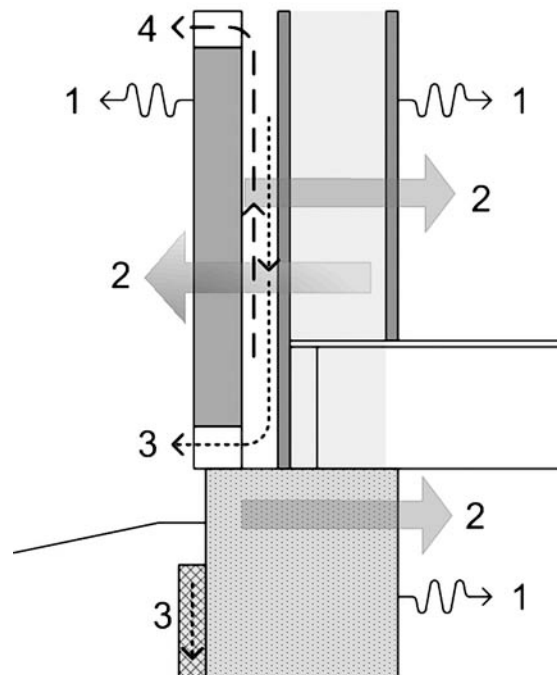

lime mortar (the latter is the most common in buildings built between the last part of the nineteenth century through the middle of the twentieth century). The interior may be exposed masonry but is often completed with parging, wood lath, and plaster. In institutional buildings, particularly those built later in the period, one or more wythes of hollow clay or terracotta tile may be added to the interior and finished with plaster. The hollow inner wythes provided both increased insulation as well as space to run plumbing services.

Load-bearing brick masonry buildings have the potential for long-term durability—it is for this reason that many still exist and are available for renovation and conversion after service lives of well over 50 years. However, the realities of escalating energy costs, increasing standards for human comfort, and the unacceptability of environmental damage due to excessive space conditioning energy losses means that modern renovations should incorporate means of reducing heat flow across the enclosure.

Historic load-bearing brickwork has a wide variety of thermal properties, but common moderate density brickwork (80 to 110 pcf) can be assumed to provide an R-value of from R0.25 to R0.33 per inch. Higher density brick (over 125 pcf) has a lower thermal resistance, about 0.15/inch. Hence, a three wythe (12") thick wall, provides an R-value of between 3 and 4 plus surface heat transfer coefficients ("air films") of another R1. If the masonry becomes wet, the R-value drops. This level of insulation is too low for most practical purposes and can even lead to condensation problems if interior humidity levels are kept too high (Bomberg and Shirtcliffe 1994). This is especially the case if a building's use is changed to a museum or gallery space. Even changing a warehouse to a loft apartment, however, changes the interior conditions sufficiently to cause a problem. Hence, for many reasons, the decision is often made to add insulation to the walls during conversion and renovations, as it is possible with the least disruption at this time.

To ensure that the goals of comfort, energy-efficiency, and durability are met, windows and roofs must also be included in the building retrofit strategy. Major improvements in the performance of these two building enclosure components can significantly enhance the overall building performance.

In many cases, the addition of thermal insulation, the reduction in air leakage, and the installation of high-performance windows not only reduce energy consumption, improve comfort, and avoid interior surface condensation, they also allow smaller, less architecturally intrusive and less expensive HVAC systems to be installed.

THE POTENTIAL FOR MOISTURE PROBLEMS IN RETROFITS

Renovating any wall can disrupt the moisture balance, and cases exist in which this disruption has resulted in damage or performance problems. The damage mechanisms of concern are primarily freeze-thaw and salt subfluorescence. Both of these mechanisms are only a problem in cold weather, and the most dangerous one, freeze-thaw, can only occur at temperatures well below freezing while the brickwork is essentially saturated (Fagerlund 1996). To avoid moisture related damage, the balance should be explicitly considered during the retrofit design process.

The addition of the insulation to the interior of a load-bearing masonry wall will lower the temperature gradient across the masonry, and reduce the difference in temperature between the masonry and the exterior air. Both of these changes reduce the drying capacity of the masonry (in particular, the diffusion drying capacity through the masonry is reduced, and the surface evaporation can be slowed). However, capillary flow is by far the most powerful moisture redistribution mechanism, and it is essentially unaffected by insulation.

Water that wicks to the interior face of the now colder insulated interior face of the masonry can still evaporate from this surface to the interior through the interior insulation and finishes during warmer weather.

Since the reduced drying capacity could result in higher moisture contents (not necessarily unsafe levels, but one often does not know the safe level with any precision), it would be prudent to also simultaneously reduce the wetting of the wall (ideally, by an equivalent or greater amount) to restore the moisture balance. Hence, an interior insulation retrofit of a masonry building requires a careful assessment of wetting mechanisms.

WETTING MECHANISMS AND THEIR CONTROL

Wetting, as described above, can occur from rain wetting, snow melting, rising damp, air leakage condensation, and vapor diffusion condensation. All need to be considered.

The largest and most intense wetting that an existing building tends to receive is that of driving rain deposition and concentration. The locations which have the highest intensity of wetting (often in the range of 10 to 100 gallons per square foot per year in the Northeastern part of North America) are the bottom corners of window openings (since windows drain and concentrate water on the lower corners) and at grade (if drainage details are not properly provided for) (Straube 2005). The control of surface rain water flow is the most critical aspect of controlling the moisture content of the masonry. Hence, reducing the wetting at these locations by the provision of projecting window sills and base drainage can often reduce wetting of the most critical areas far more than the reduction in drying caused by insulating. The role of overhangs (even projections of 1" make a material difference to wetting), belt courses, and projecting drips edges along window sills and pilaster tops cannot be underestimated. Figure 4 shows an example of a window sill which slopes away from the window, and also has a drip edge on the underside to stop water movement back to the surface of the cladding.

The addition of insulation also adds the potential for a new wetting mechanism—condensation due to air leakage. Since any insulation or new interior finishes will reduce the temperature of the interior face of the masonry in winter, as shown in Figure 5, any interior air that contacts this face could condense.

FIGURE 4. Example of sloped window sill with drip edge.



Given sufficient air leakage and sufficiently high indoor relative humidity, this condensate can accumulate faster than it can dry, and the interior face of the masonry may become saturated. To control this damage mechanism, an airtight layer to the interior of the insulation should be provided.

Finally, insulating masonry on the interior can increase the potential for diffusion-driven condensation wetting. Some vapor diffusion control is needed if both highly vapor permeable insulation is used and the interior space humidity rises too high during cold weather (above about 30% to 40% RH in cold climates). In most cases, however, the commonly specified vapor diffusion barrier of under 1 US perm is not needed. In fact, low permeance interior finishes and barriers can be detrimental to the performance as such vapor barriers resist or eliminate the potential for inward drying.

The required control of vapor diffusion wetting can usually be provided by typical latex paint, semi-

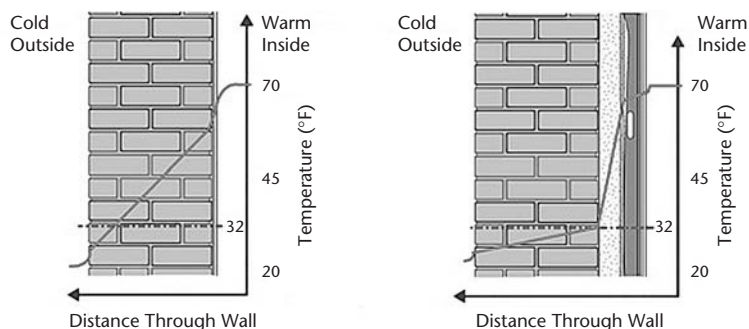

FIGURE 5. Changing temperature gradient due to interior insulation.

permeable insulation products, and other similar materials. In general, the optimal level of vapor control required can be easily calculated for specific building exposures and climates using dynamic one-dimensional hygrothermal analysis methods. We have found that the most accurate and appropriate tool is often WUFI* (Straube and Schumacher 2006).

PROBLEMATIC RETROFIT STRATEGIES

A common scheme involves drywall on a steel stud wall filled with batt insulation (Figure 6). A small (1/4" to 2") air gap may be intentionally installed on the inside of the existing masonry wall or one can form because of the dimensional variations implicit in existing buildings. The drywall finish often acts as the air barrier in this situation, and either paint, kraft facings, polyethylene sheet or aluminum foil backing

* WUFI = Wärme und Feuchte instationär (Transient Heat and Moisture) is one of the most advanced commercially available hygrothermal simulation programs in use today. Given the appropriate material data and boundary conditions, WUFI calculates heat and moisture flow every hour under the influence of sun, rain, temperature, and humidity. Its accuracy has been verified against numerous full-scale field studies of enclosure performance (www.wufi.de).

FIGURE 6. Concept drawing of stud and batt interior retrofit.

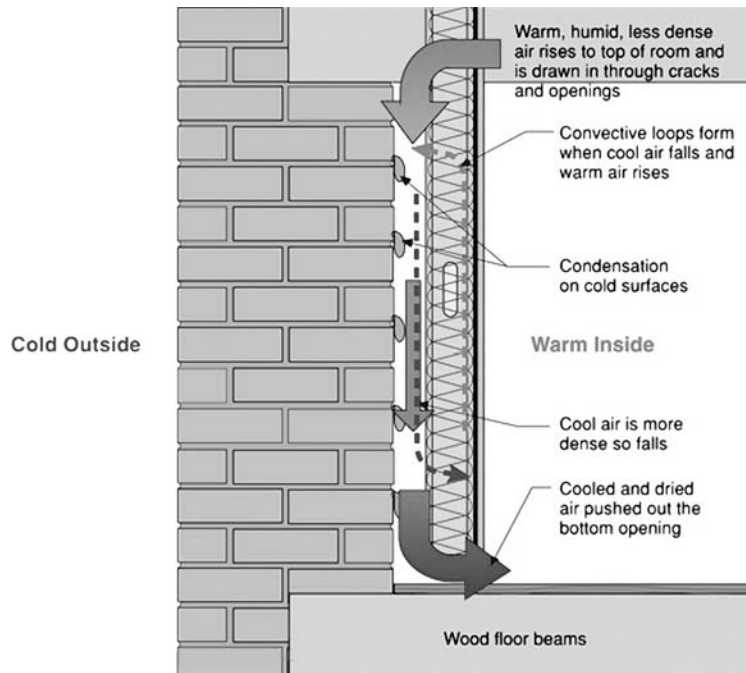

acts as a vapor control layer. (Note that multi-wythe masonry is usually quite air permeable and is not in itself sufficient as an air control layer.) There are serious problems with this approach.

First, there is a high likelihood of condensation and mold growth in the wall. As can be seen from Figure 7, if the interior conditions vary between 68°F/25%RH and 71°F/30%RH, the dewpoint temperature will vary between 32°F and 40°F. Hence, when the back of the masonry drops below these temperatures—which is likely during cold weather—condensation would occur if airflow behind the masonry were to occur. If higher interior humidities and colder outdoor temperatures are experienced, serious condensation is likely with even very small leaks past the drywall air barrier. Compounding this concern is the common propensity of pressurizing such buildings. This practice is intended to prevent comfort problems due to drafts through uncontrolled air leaks, but it also ensures that air will leak outward in sufficient volumes to cause damaging quantities of condensation on the back of the cold insulated masonry.

If steel studs are used, this approach will not provide insulation to the desired level. Steel studs are thermal bridges, and in the scenario given, are theo-

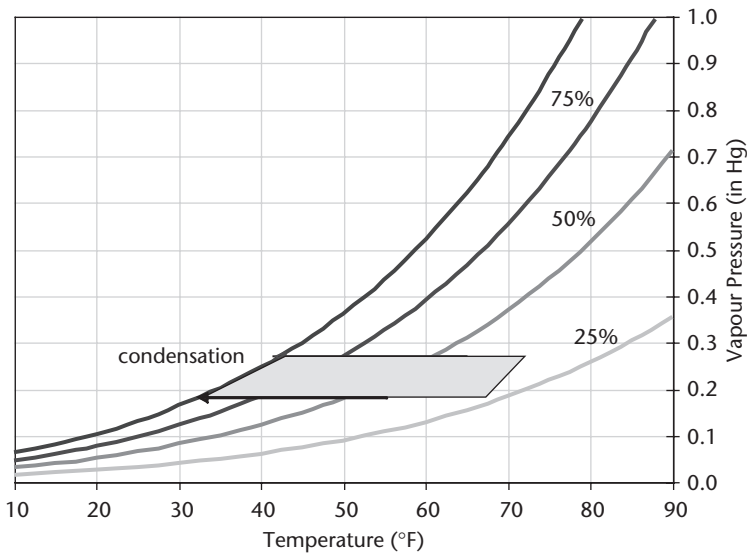

FIGURE 7. Temperatures at which condensation can occur.

retically capable of providing only about R6. In practice, installing batt between studs with no backing is very difficult, and it is almost certain that the batts will not be properly installed. Finally, air may loop within the insulation via the air gap between the masonry and the batt, reducing the R-value even further.

Hence, this scheme suffers from a number of limitations—it does not provide a reasonable level of insulation, it increases winter time wetting during the coldest weather (the same period during which there is a risk of freeze-thaw damage), and it creates a mold and indoor air quality risk. Given the serious limitations and the questionable benefits of this scheme, it cannot be recommended for any interior insulation retrofits.

SEMI-PERMEABLE FOAM INSULATION

A more successful approach involves spraying an airtight insulating foam directly to the back of the existing masonry (Figure 8). The interior finishes must all have high vapor permeance or be back-vented. This retrofit has the advantage that all air leakage condensation is strictly controlled, and it is the most practical approach to achieving high levels of airtightness in existing buildings. The use of spray foam also acts as a moisture barrier, and any small amount of incidental rain penetration will be localized and controlled. Hence, interior finishes will be protected and water will not run down and collect at floor penetrations. Water that is absorbed into the masonry can

wick to the outside (where it will evaporate and diffuse into the exterior air) or wick to the inside, where it will diffuse through the semi-permeable spray foam and interior finishes.

The application of 2" to 4" of foam after a steel stud wall has been installed is straightforward. The

FIGURE 8. Concept drawing for spray-foam retrofit.

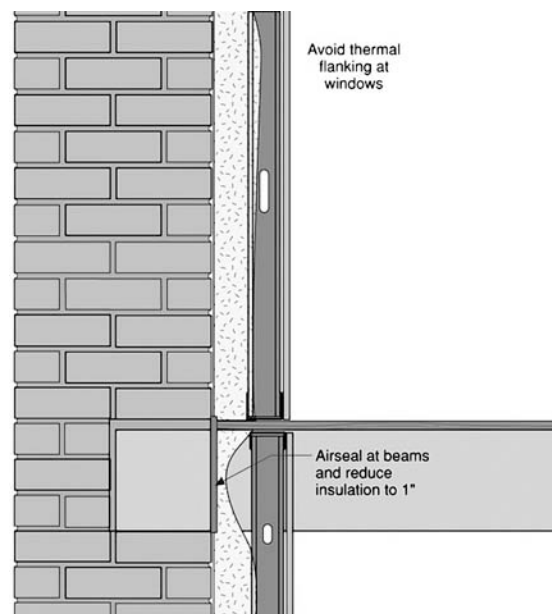
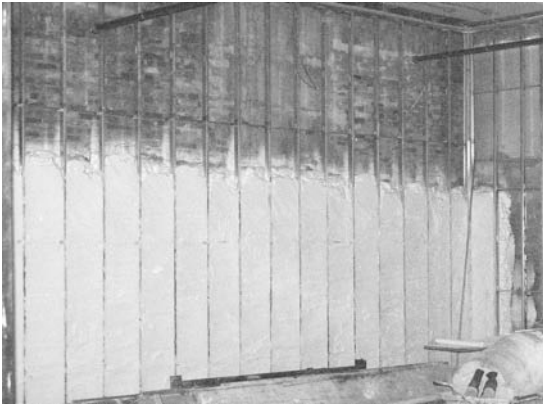

FIGURE 9. Field installation of spray foam. (Photo courtesy of Icyne®.)



empty studs space is ideal for distribution of services and allows the easy application of a drywall finish. It is best to keep the steel studs more than 1" back from the wall (2" is recommended) to allow foam to adhere to the masonry at all spots and to control thermal bridging and the moisture nanoclimate experienced by the outer flange of the studs. Figure 9 shows a field installation of spray foam against the surface of the existing masonry.

The use of this approach raises the question of the choice of interior vapor permeance for the foam. In general the interior layers should be chosen to have the highest vapor permeance possible while also avoiding wintertime diffusion condensation wetting. This strategy provides the highest level of inward drying during warmer weather. High-density closed cell polyurethane foam is generally a good solution for thinner applications (2" of closed-cell 2 pcf polyurethane foam has a permeance of about 1 perm and a thermal resistance of over R12), and some examples include BASF Walltite®, Demilec Heatlok 0240®, and NCFI Isulstar®. Open-celled semi-permeable foams (5" has a permeance of about 13 perms and a thermal resistance of almost R20) can be a good choice for larger thickness if the interior is kept at a low humidity during winter and the outdoor temperature is not too cold. Examples of open-celled foam include Icyne®, Demilec Sealection™, and NCFI Sealite™. Hygrothermal simulation can be used to identify the proper materials for a particular application (Straube and Schumacher 2003).

In many cases rigid foam board insulation of various types has been used as the interior retrofit. For thin layers of insulation, a semi-permeable foam such as extruded polystyrene or unfaced polyisocyanurate can be used, but for thicker layers the more permeable expanded polystyrene board are preferred. This method has been used successfully, but is far more difficult to build as it requires great care in ensuring that the board is firmly in contact with the masonry (any gaps may allow convective loops to transport moisture and heat), and that a complete air barrier is formed. Figure 10 shows a building that was in part retrofitted by installing rigid foam directly on the interior of the masonry. A liquid-applied, highly vapor-permeable air and water barrier should be applied to the back of the masonry. This prevents any localized water leakage from penetrating and collecting at floor penetrations. The coating also acts as the primary air barrier, while being vapor permeable to allow water vapor to move in either direction. The foam boards should be attached with serpentine patterns of adhesive. An interior air flow retarder, perhaps in the form of taped and sealed joints, is also required to prevent interior air from contacting the cold masonry.

ADDRESSING STRUCTURAL PENETRATIONS

The floor structure inevitably penetrates into, and rests on, the masonry walls in these buildings. Occasionally this occurs at pilasters, but it is more com-

FIGURE 10. The University of Waterloo School of Architecture building in Cambridge, Ontario, was insulated in part with rigid foam board insulation on the interior.



mon for either large wood beams or concrete slabs to transfer the floor loads to the walls. When the structural connection is via concrete slabs, there are no real durability concerns. However, the conductive concrete can cause sufficient heat loss to make the interior surfaces of the concrete cold. Depending on the interior finishes, the exterior temperature, and the interior relative humidity, surface condensation may become a problem. There are a number of solutions if thermal bridging becomes a problem, including topical and targeted application of heat and/or reduction in interior humidity as well as insulation strategies. Two-dimensional heat flow analysis is an invaluable tool for assessing the impact of surface temperatures and heat flow.

The most challenging scenario is one in which wood beams penetrate the new interior finish and rest in pockets within the masonry. The goal must be to reduce all air leakage that carries moisture into this cold beam pocket. Providing ventilation to this space is almost certain to cause condensation, not avoid it.

FIGURE 11. Concept drawing of pressure controlled interior retrofit.

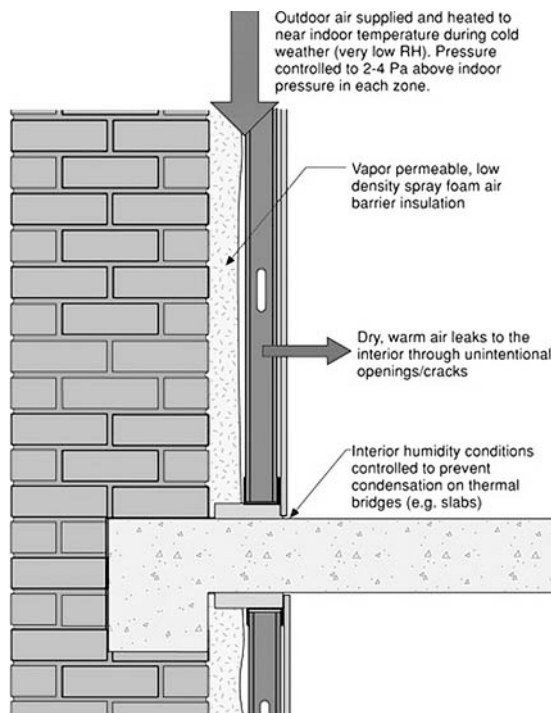

However, it is desirable to allow some small amount of heat to flow into this space, as this will allow for some drying of the wood relative to the colder (as it is better insulated) masonry around it. If the beams are as infrequently spaced as 6 or 8 feet, then the approach shown in Figure 8 is recommended—that is, air seal caulking and foam is provided around the beam, and thinner interior foam would be used at this location. In some cases, small heat sources can be provided in the beam pockets via highly conductive metal wedges driven alongside the beams.

ALTERNATIVE METHODS

The use of semi-permeable foam insulation in contact with the back of the existing masonry is the most common successful strategy for interior insulation retrofits. The use of air and vapor-permeable batt or semi-rigid insulation is, in our experience and analysis, a risky solution that cannot be recommended.

In some cases the masonry is sufficiently damaged that rain penetration can be expected. If exterior repairs and re-pointing cannot control this type of rain leakage, a drainage space may be necessary behind the load-bearing masonry. Forming a drainage gap and installing a drainage plane is not difficult, but achieving the required, and critical, flashing details can be a formidable challenge (particularly around structural floor penetrations). If this approach is taken, it is still necessary to provide very good airtightness.

For applications that require a high (over about 40%) relative humidity during the winter, it may be necessary to control airflow by pressurizing the space between the insulation and the interior finish with low humidity air (Figure 11). This allows for thinner layers of insulation to be applied, as the airflow ensures that the interior finishes are at interior temperature regardless of the heat flow through the wall. As the air next to the insulation layer is very dry, it allows highly vapor permeable open-cell foam to be chosen and encourages evaporative drying to the interior. The most common choice of air supply for this application is the exterior air, heated to interior temperatures. This method of interior retrofit is the most complex, the most expensive, and the most energy intensive. However, it is chosen on occasion (e.g., for historically significant museum buildings) because it also allows the most inward drying and changes the moisture balance the least of all options.

SUMMARY

Insulating load-bearing masonry buildings on the interior in a cold climate is usually required to meet human comfort requirements, environmental goals, and operating cost targets. Many such interior retrofits have already been successfully completed in cold climates by the use of a continuous insulation level combined with attention to airtightening and exterior rain shedding details.

The use of semi-permeable foam insulation in contact with the back of the existing masonry is the most common successful strategy for interior insulation retrofits with a track record of success. This method also has the advantage of being one of the most practical to achieve under field conditions. The use of air and vapor-permeable batt or semi-rigid insulation is in our experience and analysis a risky solution that cannot be recommended.

To ensure that the goals of comfort, energy-efficiency, and durability are met, windows and roofs must also be included in the building retrofit strategy. Major improvements in the performance of these two building enclosure components can significantly enhance the overall building performance.

To further reduce the likelihood of moisture problems in the building enclosure, the mechanical

systems should be designed and commissioned to avoid any positive pressurization of the building. Humidity also needs to be controlled, particularly in cold weather.

REFERENCES

- Bomberg, M.T., and C.J. Shirtcliffe. 1994. "A Conceptual System of Moisture Performance Analysis." *Moisture Control in Buildings, ASTM Manual, Series No. 18*, ed. H.R. Trechsel, Chapter 26.
- Fagerlund, G. 1996. "Assessment of the Service Life of Materials Exposed to Frost." *Durability of Building Materials and Components 7 (Volume One)*. London.
- Straube, J.F. 2005. "Driving Rain Data for Canadian Building Design." Proc of 10th Canadian Building Science and Technology Conference, Ottawa, May 12–13.
- Straube, J.F., and E.F.P. Burnett. 2005. *Building Science for Building Enclosure Design*. Westford, MA: Building Science Press.
- Straube, J.F., and C.J. Schumacher. 2003. "Hygrothermal Enclosure Models: A Comparison with Field Data." Proc. of 2nd Int. Conf. on Building Physics. Leuven, Belgium, Sept. 14–18, pp. 319–326.
- Straube, J.F., and C.J. Schumacher. 2006. "Assessing the Durability Impacts of Energy Efficient Enclosure Upgrades using Hygrothermal Modeling." *Journal of the International Association for Science and Technology of Building Maintenance and Monuments Preservation*, Vol. 2.